

FOLLY / FUNCTION

2017



FOLLY / FUNCTION

2017

Socrates Sculpture Park
32-01 Vernon Boulevard
Long Island City, NY 11106 USA
socratessculpturepark.org

Socrates Publishing 2017





TABLE OF CONTENTS

7
about FOLLY / FUNCTION competition

8
INTRODUCTION

14
about CIRCLE SHADE $2\pi R^4$

19
INSPIRATION & POETICS

25
the CANOPY

34
JOINT NODES & BRACKETS

40
the COUNTERWEIGHTS

55
FINALISTS

64
NOTABLE ENTRIES

78
about EVA JENSEN DESIGN

85
SUPPORT & THANKS





about FOLLY/FUNCTION competition

Folly/Function is an annual juried competition engaging architects to design and build a project for public presentation at Socrates Sculpture Park. Jointly directed by The Architectural League of New York and Socrates, the program addresses the intersection of architecture, sculpture, and public space. The program began in 2012 as Folly, inviting architects to propose and then build a capricious, non-utilitarian structure—architecture approaching sculpture. For five successful years the program presented inventive, whimsical, and dramatic projects before shifting emphasis towards architecture's expertise and relaunching as Folly/Function.

Previous winning proposals of the collaborative competition are *Sticks* by Hou de Sousa (2016), *Torqueing Spheres* by IK Studio (2015), *SuralArk* by Austin+Mergold (2014), *tree wood* by Toshihiro Oki architect p.c. (2013), and *Curtain* by Jerome W. Haferd and K. Brandt Knapp (2012).

INTRODUCTION

Sometimes you have to stand back and look at what is happening. Our 2017 Folly/Function project came from observing how well the Park achieves its purpose as a public art venue, a highly programmed social space, and urban waterfront park. Last year, through our collaboration with The Architectural League of New York, Socrates Sculpture Park changed the focus of our design competition from Folly to Folly/Function and began identifying aspects of the Park that could benefit from the extraordinary talent of architects and designers by developing a design-build project that improves the aesthetic experience of the Park, acts as a resource for our community partners, and facilitates our programming.

The result in 2016 was *Sticks*, an outdoor pavilion designed by Hou de Sousa, for our arts education area. This enormously successful design-build project encouraged us to look elsewhere in the Park for opportunities for improvement. The 2017 Folly/Function project, *Circle Shade – 2πR4* by Eva Jensen Design, has proven equally successful, by replacing nondescript tents used frequently in the landscape with remarkably designed and exquisite shading structures.

The challenge of the 2017 Folly/Function competition, spectacularly achieved by Eva Jensen and her team, was to design a shade structure that is portable, easily assembled, and provides an elegant object that amplifies Socrates' three pillars of purpose as a public art venue, social space, and park. The following publication delves into the meticulous design process for the creation of *Circle Shade – 2πR4*, in addition to other noteworthy and ingenious structures proposed for the competition.

I want to thank our partners The Architectural League of New York and their staff; Jess Wilcox, Director of Exhibitions at Socrates, for her astute contributions and coordination of this publication; our Board of Trustees for their support and enthusiasm for art and architecture at the Park; and the Graham Foundation, whose partnership has made this design-build project possible.

John Hatfield
Executive Director
Socrates Sculpture Park







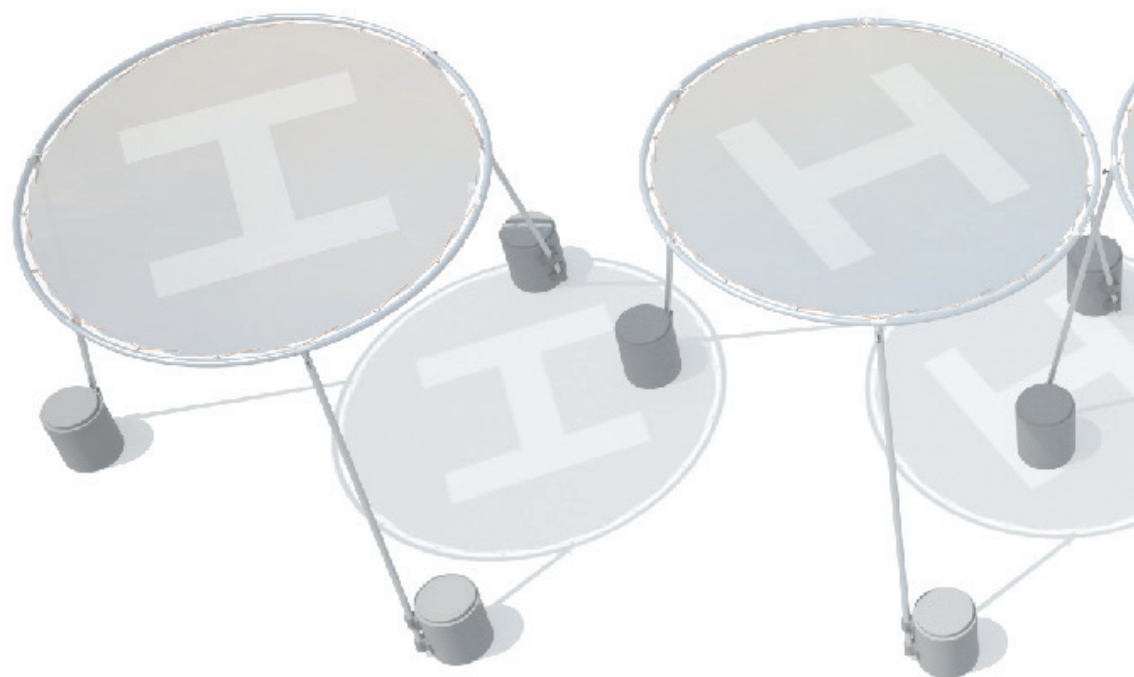

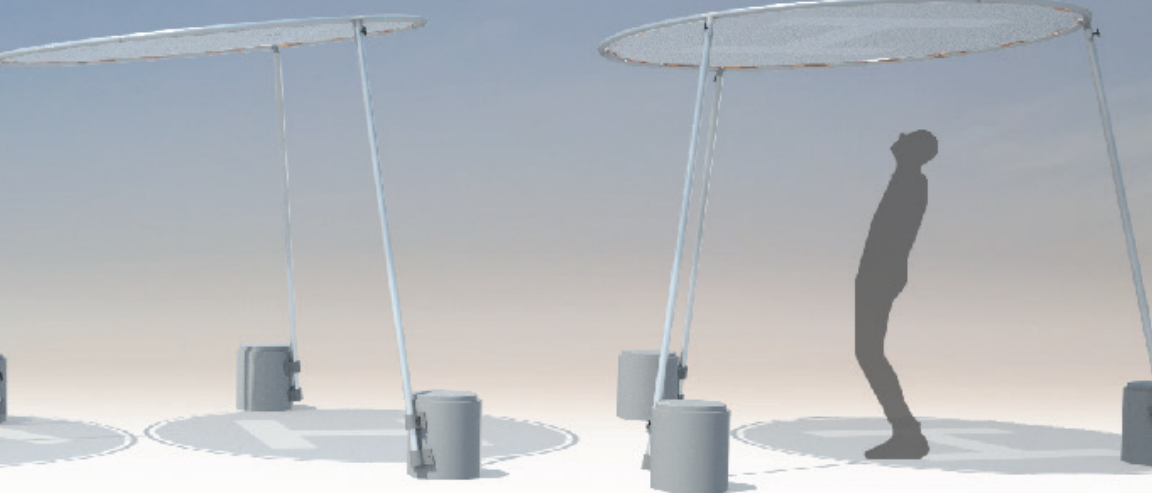

about

CIRCLE SHADE-2TR4

Circle Shade – 2πR4 is a refined, portable, demountable canopy system designed and developed by my team at Eva Jensen Design as a kit-of-parts for quick assembly. The design vocabulary is minimal and clean, based on the structural tripod concept, with 3D-printed nodal connections. A single unit consists of three main components encompassing seven parts: one canopy, three poles and three cylindrical counterweights. To connect these basic elements, we designed custom 3D-printed joint nodes. The circular canopy was conceived as a large ring that can be rolled for ease of mobility, and was inspired, in part, by wheels we observed during a visit to Socrates Sculpture Park. The circle canopy crowning the structure also displays Socrates' logo. The supporting poles are anchored by counterweights that serve as seat, back rest, table top, or step stool for use during set up. *Circle Shade* structures can be erected as a single unit or deployed in a series for gatherings and social events. In this way, they adapt to a range of settings from park landscapes to waterfront and urban environments.

By Eva Jensen

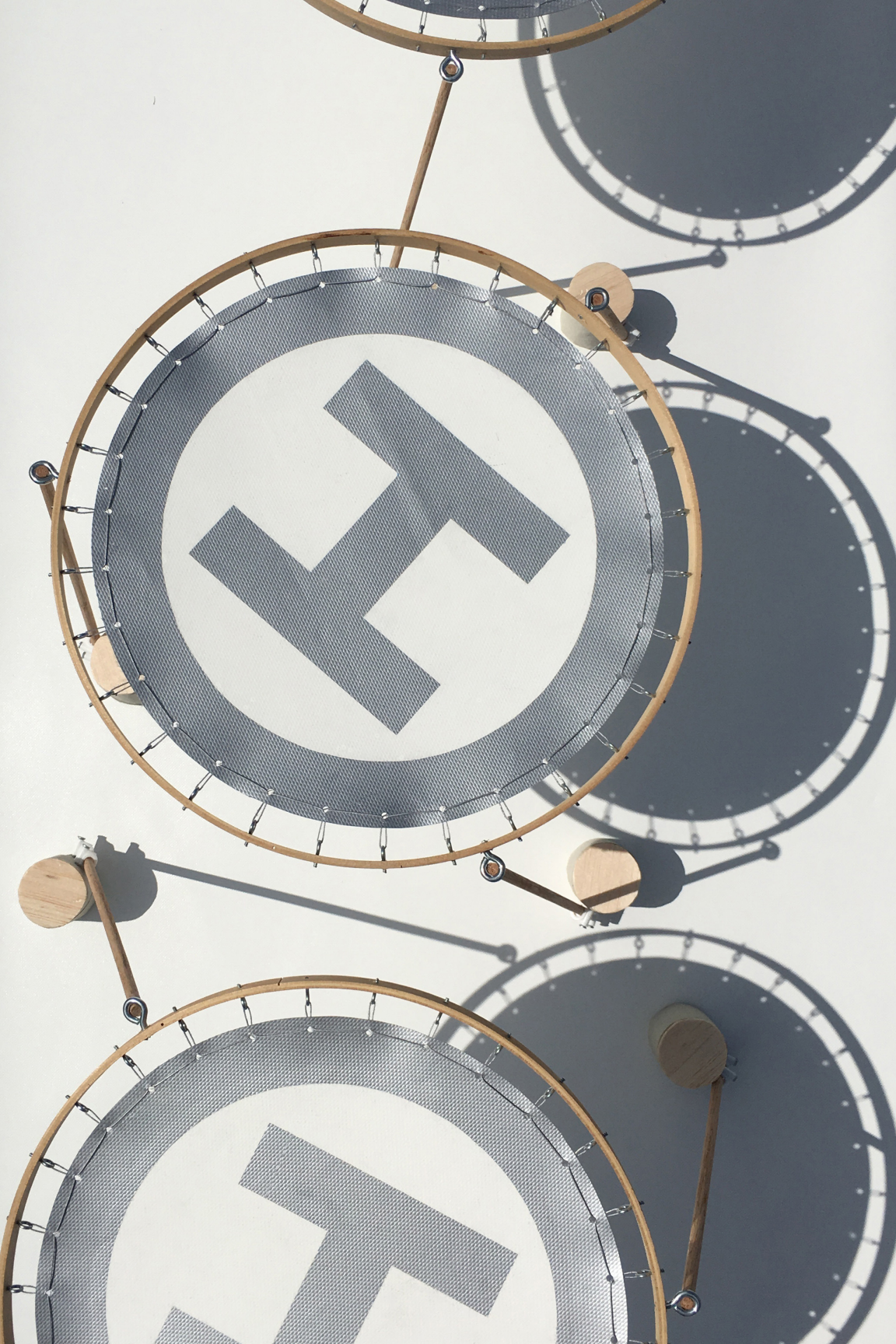



CIRCLE SHADE 2TR4

EVA JENSEN DESIGN

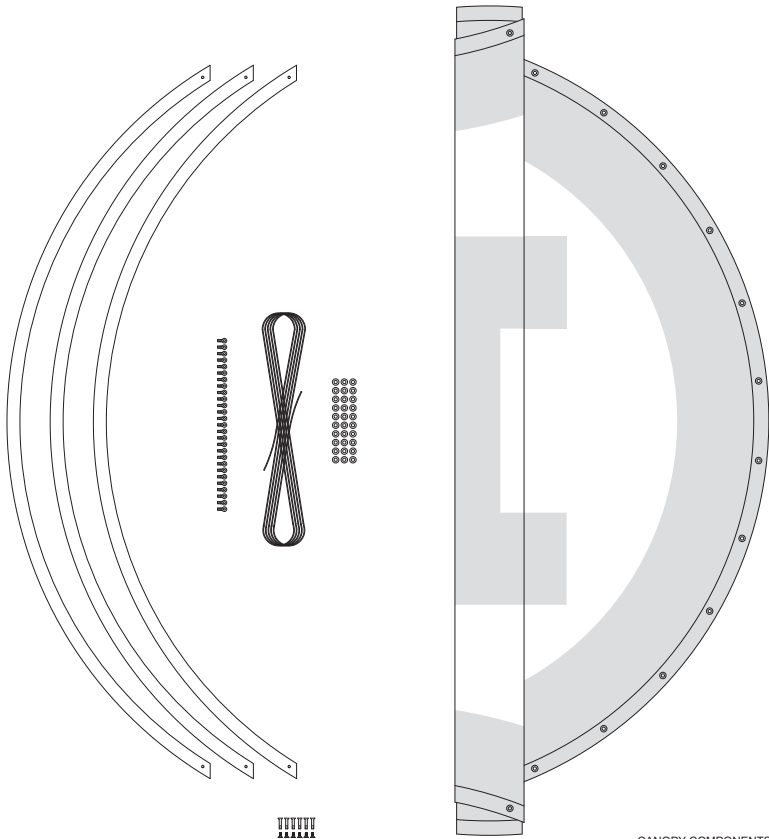

CANOPY COMPONENTS



POLES & PINS

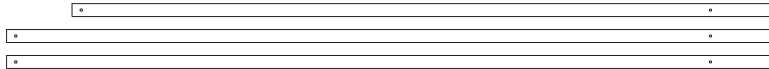

COUNTERWEIGHT COMPONENTS

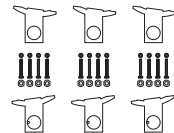
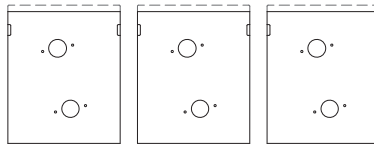

DRAWING SCALE 1:2

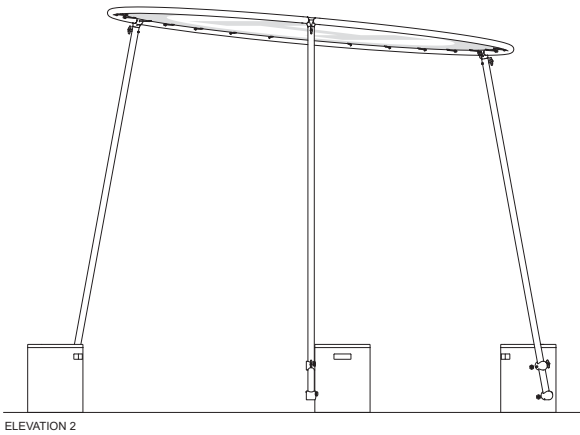
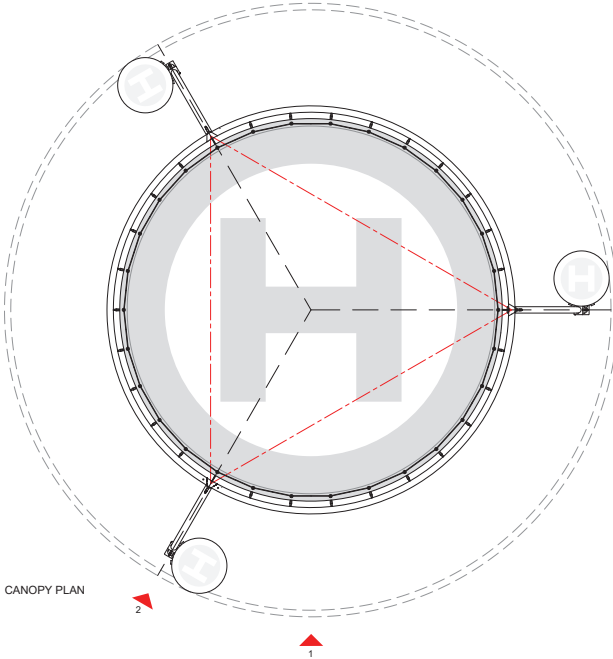
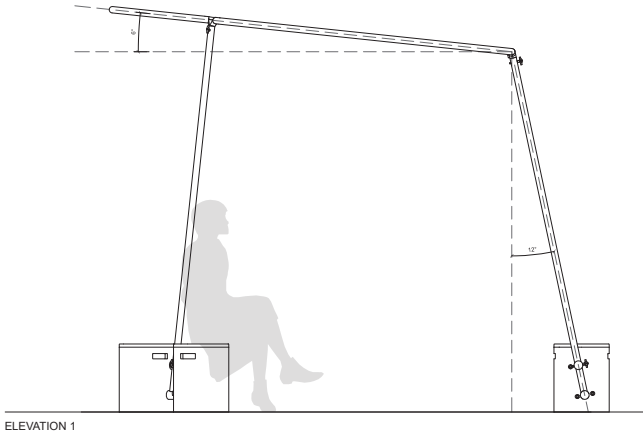

INSPIRATION & POETICS

The *Circle Shade* unit is composed of two fundamental geometries—the circle and the triangle—that shape and define the design DNA from overall structure to the intricate detailing of the 3D-printed joint node connectors. We conceived the structures as minimal tripods anchored by weighty feet, each radiating the energy of a wheel. As a constellation in the landscape, a playful composition of dynamic structures emerges, casting restful rhythms of round shadows punctuated by a faster beat of cylindrical drums.

Prior to the actual residency, we spent time at Socrates Sculpture Park working in our studio to develop the details for fabrication by creating models, mock-ups, and 3D test prints of the joint nodes and counterweight brackets. Early in the process, we determined how much we could fabricate ourselves with the tools available at Socrates' workshop, and which parts required specialized machinery and skill sets.



YIP HO FAT

TOP SURFACE CENTERLINE

TOP SURFACE OUTER EDGE

TOP SURFACE CENTERLINE

TOP SURFACE OUTER EDGE

RI-102 INTERIOR RADIUS OF RING

RI-112 CENTERLINE RADIUS OF RING

RE OF EXTERIOR RADIUS OF RING

BOTTOM HOLES TO BE
DRILLED IN SITU AT 50° UP

BOTTOM CUT ALL LESS

The ring segments required professional tooling. We looked to Z-Studios, one of the few Long Island City-based workshops that had the bending dies for the aluminum tubing we specified. The material complexity of the shading membranes and concrete counterweights also required us to seek assistance from specialized workshops.

At the Park's studio, we cut, drilled, and finished the aluminum poles and ring segments. In order to control the precision necessary for the assembly hardware, we developed CNC-milled and 3D-printed jigs to assist the process. We finished the Russian birch plywood seats for the counterweights and applied the Socrates logo to the shading membrane. While at Socrates, we also tested the assembly of the aluminum frame structure. Once we received the concrete counterweights, assembled the rings, and laced the membranes to the frame to finish the canopies, we completed the kit-of-parts, and the *Circle Shade* units were ready.

It was beautiful to experience the spring season at Socrates Sculpture Park, and our working on-site provided an opportunity to interact with both the studio staff and the visitors. As we worked outdoors, we were often exposed to the Park's numerous events and public programs. In this way, we got a head start introducing the *Circle Shade* project to the general public.

Inspired by this experience, I decided that it would be beneficial to synthesize the design-build process for an exhibition on view during the opening of *Circle Shade*. I sought to shed light on the design's development and enable visitors to draw connections between process and finished product. The exhibition displayed a selection of the work models, full-scale mock-ups, hardware, tooling, and jigs, all accompanied by a choice of fabrication drawings. It told the story of the design's engineering and its iterations.

By Eva Jensen

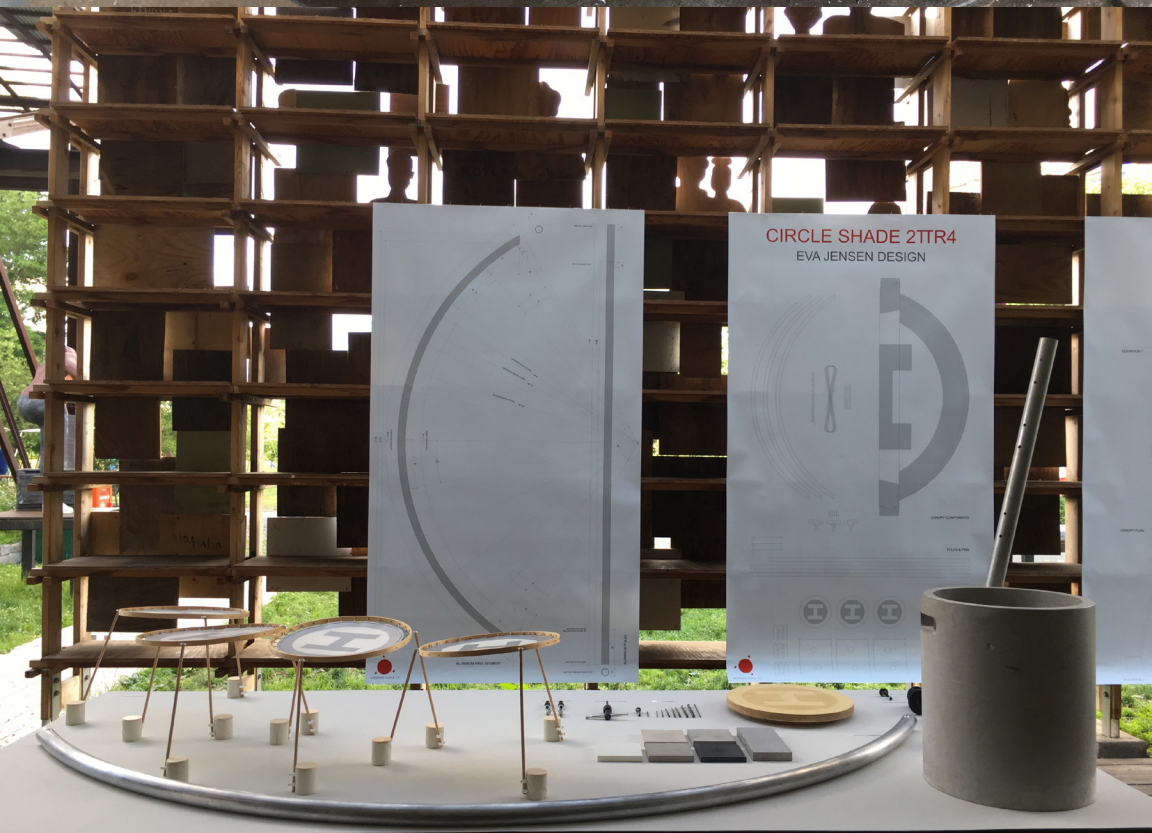

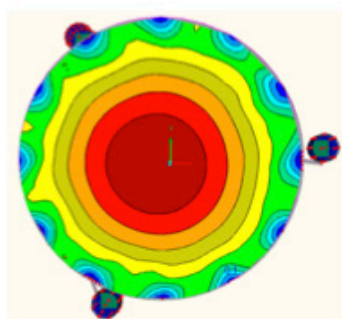
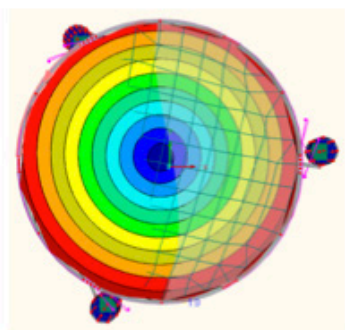
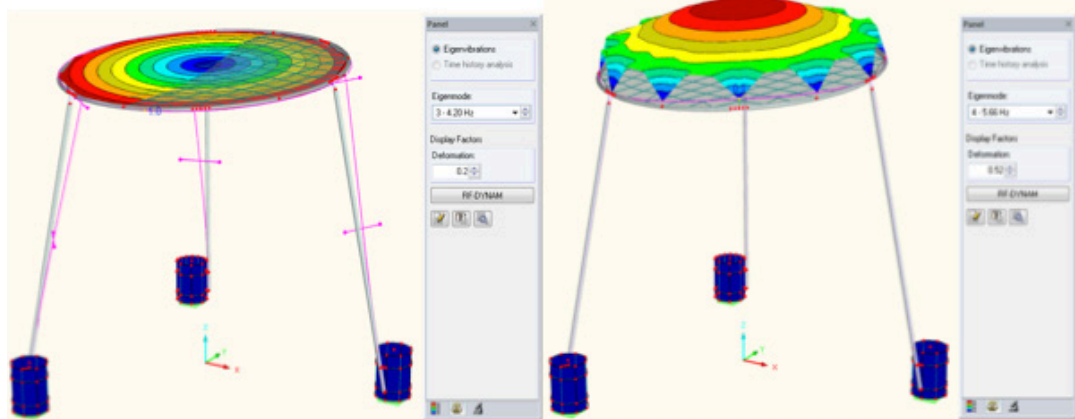

THE CANOPY

Three segments of custom-bent aluminum tubing form the circular canopy. Each is connected by three-pronged 3D-printed joint nodes that we custom-designed in collaboration with Laufs Engineering Design. A static “Dyneema” rope line fastens the aluminum frame to the shading membrane by threading through the frame’s eye bolts, grommets located on the perimeter of the shading membrane, as well as through the embedded channels of the joint nodes themselves. Aluminum support poles are connected to the vertical prongs of the joint nodes. The canopy tilts six degrees and is fixed in place by T-handle pins.

The fabrication of the canopy membrane proved to be one of the more challenging parts of the design. We sought a material that offered breathability, a translucent quality, and a texture that would allow for the logo to be printed. After extensive research and testing, we came upon a new-to-market outdoor solar shade produced using nanotechnology and woven in a twill pattern. At Manhattan Shade and Glass' Long Island City studio, we collaborated with technicians to determine the final membrane edge detail. The canopy membranes were machine-cut, but had to be completed manually using sewing machines.

By Eva Jensen





$R3-10\frac{1}{2}"$ INTERIOR RADIUS OF RING

$R3-11\frac{1}{2}"$ CENTERLINE RADIUS OF RING

$R4-0"$ EXTERIOR RADIUS OF RING

12°

10°

30°



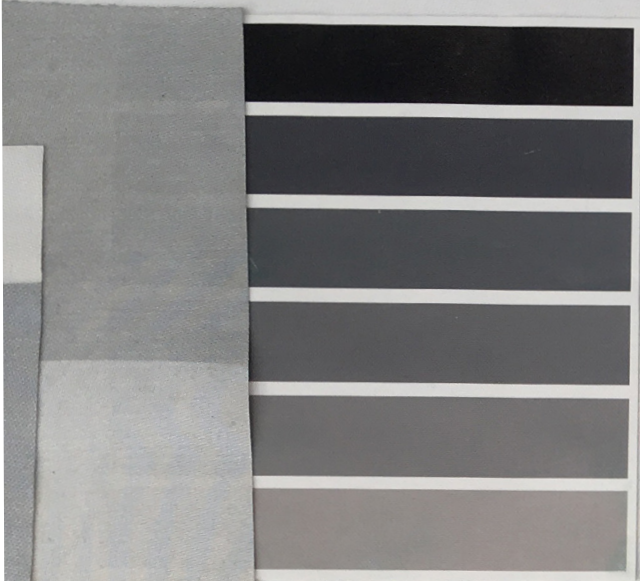

MEMBRANE PAINT STUDIES



DYNEEMA UHMWPE FIBER ROPE SAMPLES

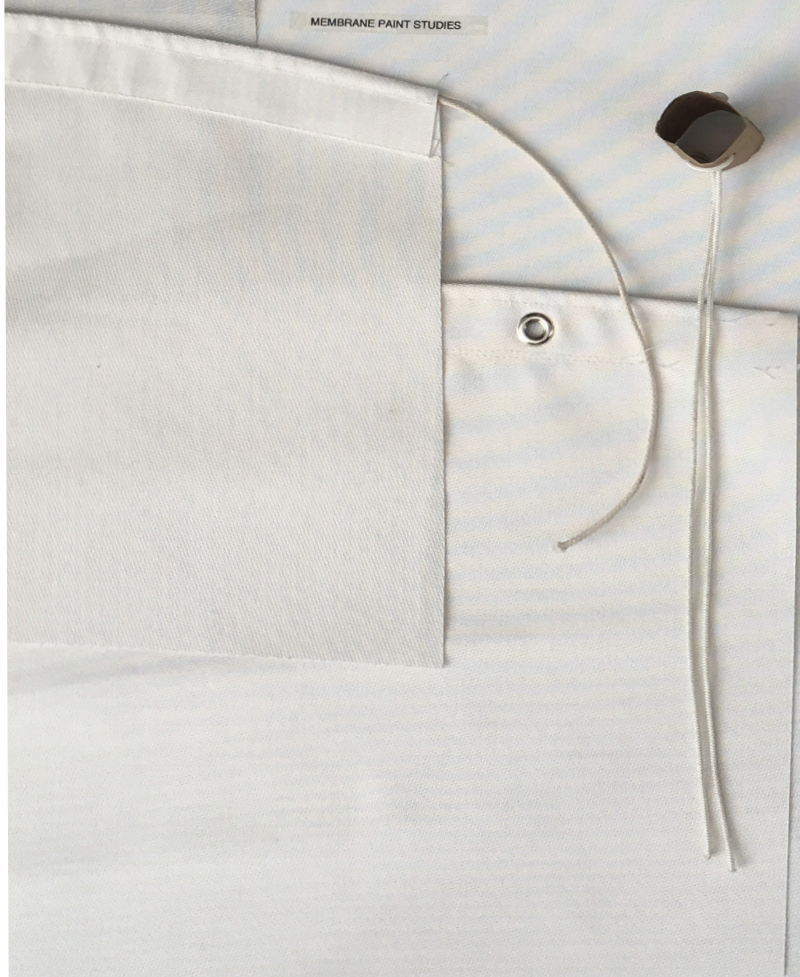

MEMBRANE HEM STUDIES



ENDURA 12 DYNEEMA STATIC ROPE

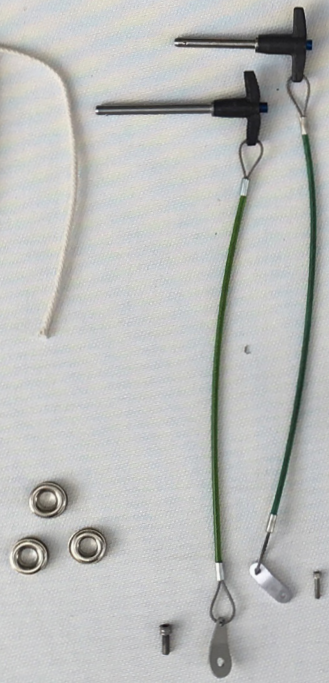

T-HANDLE CONNECTOR PINS



NODE 1-FIBER REINFORCED NYLON



NODE 2-KEVLAR W/ EMBEDDED CHANNEL



NODE 3-NYLON W/ CLEAT



NODE 4-CARBON REINFORCED



ALUMINUM ENGRAVING TEST



EYEBOLT-RING CONNECTION MOCK UP

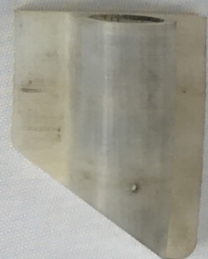

3D PRINTED FABRICATION JIGS



MEMBRANE RING EYEBOLTS



ALUMINUM RING SEGMENT CUTS

CNC MILLED FABRICATION JIG

LED 3D PRINTED NODE ITERATIONS





JOINT NODES & BRACKETS

The concept for *Circle Shade* was conceived and developed in CAD software. For structural analysis of the four outdoor mobile canopy systems, we consulted structural engineer Laufs Engineering Design (LED), whose office is located in Long Island City near Socrates Sculpture Park.

The initial collaboration explored the joint nodes' structural properties so that they could efficiently support a segmented eight-foot diameter ring and further enable it to sit on a tripod stabilized by counterweights. LED had experience using 3D-printing to fabricate canopy structures and their research demonstrated a range of customization methods that allowed for a more liberating formal exploration that pushed the limits of the joint nodes' functional capabilities.

Initially, the ring's joint nodes were developed with a printed protruding eye-hook for lacing of the canopy to the ring. However, the 3D-printer was not able to place reinforcement fiber in this element, and, therefore, it was susceptible to breaking.

During the design development, we turned this particular 3D-print fabrication challenge into a guiding design parameter. We saw an opportunity to customize the joint nodes even further using 3D-printing technology to incorporate internal channels that served as conduits for the static “Dyneema” line that tethered the shading membrane to the aluminum ring. Thus, the joint nodes became an integrated design element serving to link the elements of the canopy with one another, the tripod poles, and the shading membrane.

The 3D-printed counterweight brackets underwent parallel design development. Initially, they were designed as externally applied half-circular brackets with flanges for mounting. Through the design process, they became a pair of clean and simple offset cylinders protruding through holes in the curved face of the concrete counterweight with hidden interior curved plates for mounting. 3D-printing allowed for an iterative design process that honed the customization of specific parts.





Laufs Engineering explains joint node fabrication process at their studio in Long Island City

The three-cleat node was a further iteration, and a gesture to provide for a start and finish of the fastening lace, allowing for future adjustments.

The focused design iterations took advantage of 3D-print customization, as each node is slightly different. Prototyping during design development was only possible for certain parts: the 3D-printed joint nodes and brackets, the membrane, and the concrete counterweights. The four *Circle Shade* units produced are fabricated as prototypes created through 3D computation and model studies.

By Eva Jensen

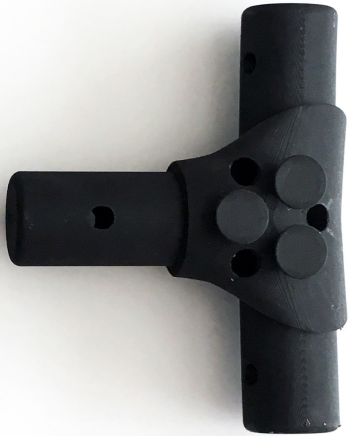
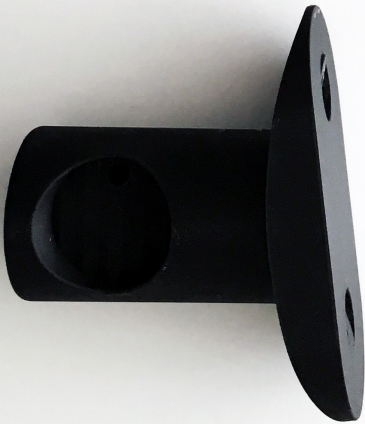

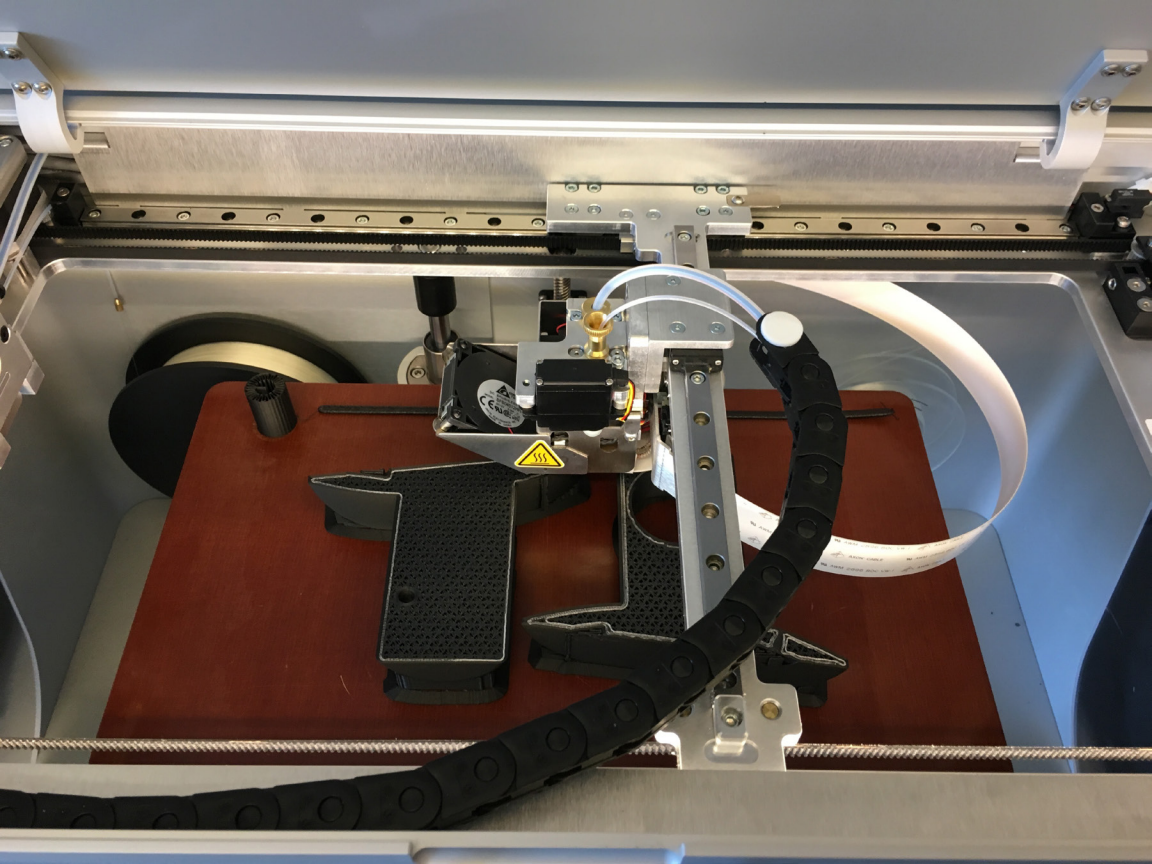

THE COUNTERWEIGHTS

Each *Circle Shade* structure is anchored by three cylindrical counterweights. The drums also function as stepstools for access to the canopy ring during assembly, as well as seats for visitors of the Park. The New York-based company Truth Concrete mold cast the concrete forms with fiberglass and other aggregate for reinforcement and weight control. Each counterweight includes two openings for handling and a removable plywood top. On the sides of the counterweights, two offset cylindrical brackets protrude to hold aluminum poles in place at a 12-degree angle. The upper cylindrical bracket allows for the pole to pass through, while the lower brackets provide for an elevated base with drainage. The brackets are fastened with bolts mounted into 3D-printed grommets integrated with the interiors of the counterweights. The brackets, like the joint nodes, are 3D-printed and fabricated out of a nylon-carbon fiber composite with fused filament technology.

By Eva Jensen















ASSEMBLY

1. The circular canopy rolls out with ease, and is placed flat on the ground for set up.
2. Three aluminum poles, one shorter and two longer, are laid out in extension of each of the three canopy joint nodes. The differentiated three-cleat node is for the shorter.
3. The poles are inserted into the node legs, and the canopy is raised into position on the poles.
4. The three counterweights are set up beside each of the tripod legs.
5. Next, the structure is lifted, and the poles placed inside the pair of offset counterweight brackets.
6. A T-handle pin at each of the six pole connection points fixes and stabilizes the system. The counterweights serve to ground the structure, and prevent uplift. The visitor is invited to take part in anchoring the unit.





2



1



3



4



6



5





Folly/ Function 2017

**Call for
proposals**

**A design/build
competition
organized by
Socrates
Sculpture Park
and The
Architectural
League
of New York**

THE COMPETITION JURY

This year's competition called for jurors who could evaluate designs that had the potential to enhance the landscape of Socrates Sculpture Park, the traditional role of an architectural folly, while also efficiently serving a durable function. That the structures also needed to be demountable, portable, and easily redeployed added an additional layer of complexity in assessing the entries. The combined architectural, engineering, artistic, and curatorial expertise of the jury—comprised of Tatiana Bilbao, Eric Bunge, John Hatfield, Mary Miss, Craig Schwitter, Hayes Slade—provided the basis for an informed and lively evaluation of the entries, from the aesthetic impact of each structure individually and in aggregate, as well as their ease in assembly, stability, and durability.

FINALISTS

Finalists and notable entries to this year's Folly/Function competition harmonized both formal and functional properties by referencing and experimenting with pervasive architectural forms and vernacular styles. The proposals demonstrate variable interpretations of communal use while considering how the portable shading structures might relate to the elements, the site, and one another.

By Akiva Blander

FOLLY/FUNCTION

FINALIST

Jason Bond's proposal *Twins* seeks to “break the passive observation of the viewer” by distorting the symmetry of the “vernacular pipe-framed canopy,” enabling any number of unusual aggregations among the modules. Asymmetry is achieved in two ways: a trapezoidal plan that departs from a conventional rectilinear canopy supported by four regularly-spaced legs, and an added diagonal ridge pole across the top, creating a roof that subverts the typical mono-pitch canopy.

Each module is comprised of an (asymmetrical) aluminum tube frame, 3D-printed plastic joints, and adjustable feet, topped by a polyester-backed diamond foil mylar canopy top. When combined, their asymmetrical relationship facilitates a variety of Park activities, and moves beyond just “a single coherent roof form.” Individually, modules can host smaller-scale activities, or may be aggregated in larger continuous, winding conglomerations.



Line

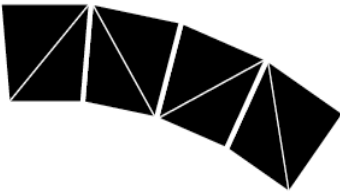
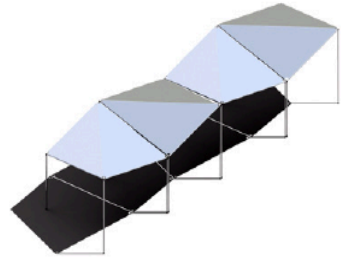

Curve

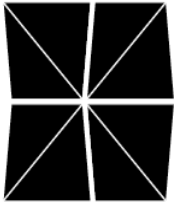
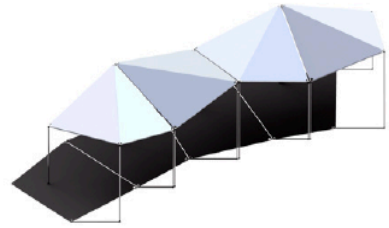

Quad

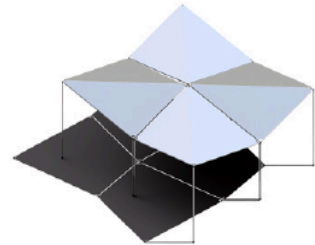

By imposing forced perspective, a departure from the typical encounter with a conventional canopy, *Twins* simultaneously entertains and challenges the viewer, by combining eccentricity and elegant utility. The reflective nature of both the shading structure's structural components and materials ensures a visually and programmatically dynamic experience.





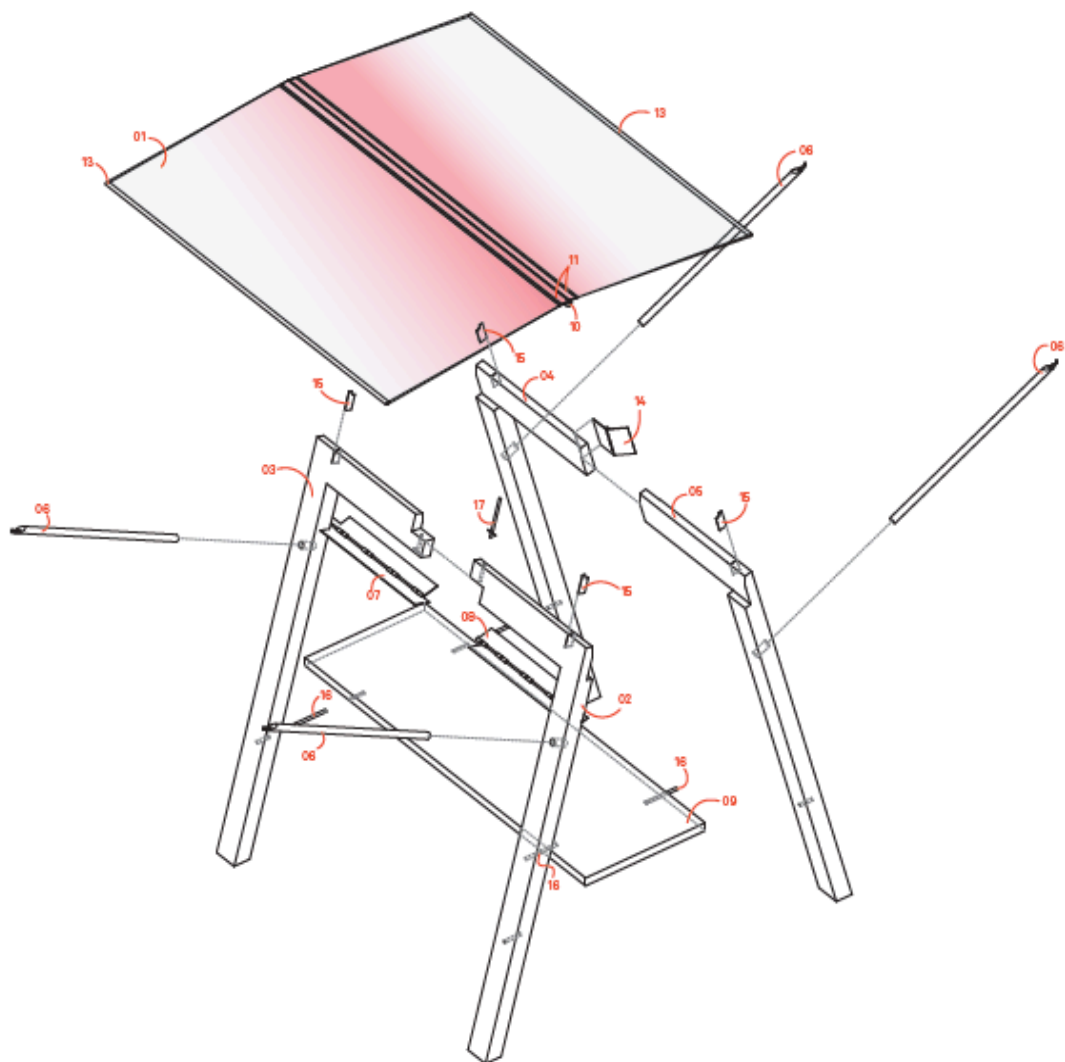

FOLLY/FUNCTION

FINALIST

Alice Song, Ronnie Kataki and Edward Wang of **Nice One Projects**, propose *Nice Huts*, a set of six units each composed of an A-frame trestle supporting an adjustable, vinyl canopy. They are inspired by the “humble mechanics of the wood table trestle,” which, in this iteration, enable programmatic flexibility even within the constraints of its structural fixedness and material rigidity.

Each hut’s double-hinged lumber frame “legs” enable easy storage and assembly. Wood support “arms” extend horizontally from the tops of the legs, supporting the durable vinyl canopy offering several configurations. Depending on the desired function, the four arms can be held up or let down, creating tent-like arrangements.

The huts’ communal value is evident in the central table surface that invites collective use, from a neighborhood potluck to a community meeting. By suggesting “the idea of inviting local artists and designers to help us create... custom canopies,” the designers further implicate the public as a party in using and shaping this collective space.



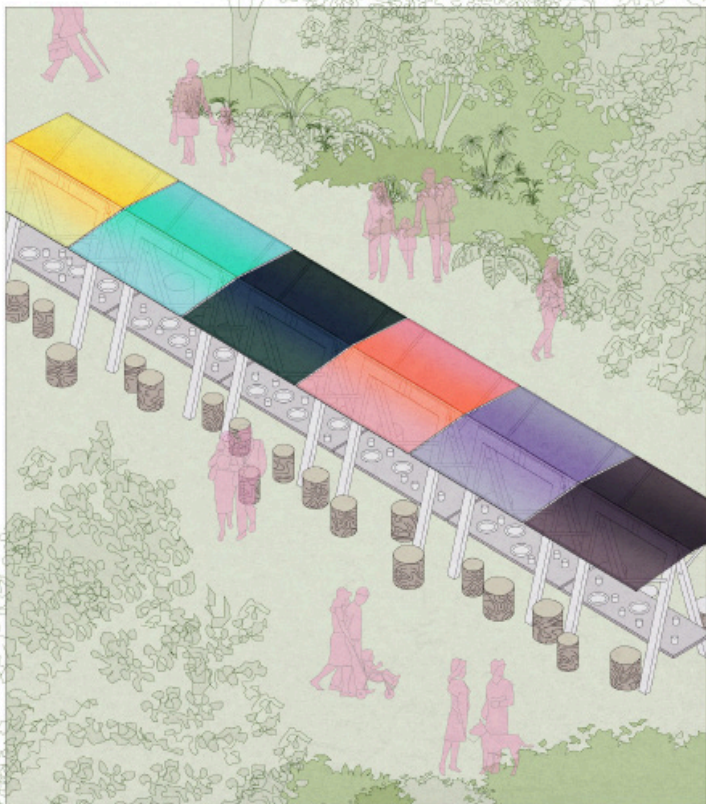
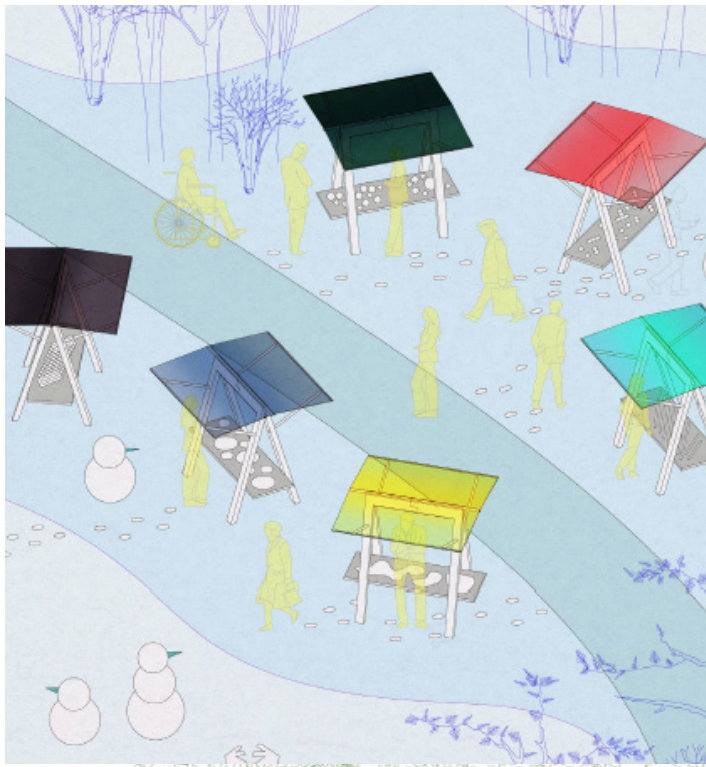

NOTABLE ENTRIES

By Akiva Blander

Kathleen E. Clark and **Gregory K. Serweta**'s proposal *Parachute* adapts the “familiar, yet magical” form of “a simple flat sheet” into a stable yet “billowing” park structure. Tethered to the ground by steel anchors and structurally supported by PVC pipes, the pop-up tent opens on all sides to simultaneously protect users from the elements above and invite a host of programmatic uses below.





Plug and Play, a proposal by **Christian Kotzamanis** and **Miquel Salva Tejedor**, presents a kit-of-parts comprised of fabric squares and wood posts weighted at their bottoms. The corners of the horizontal fabric square are attached to the vertical posts by ropes and through eyelets, creating a pulley system that enables modifications to the height, angle, and orientation of the “ceiling” depending on purpose, location, and time of day. Individual tent-like structures, when placed adjacent to one another, expand *Plug and Play*’s utility and sculptural form.





Primitive Hats by **office ca** proposes a simple and elegant folly “structured similar to a folding chair,” making the structure easily constructible, collapsible, and transportable. The perpendicular steel-piped frames are topped by weatherproof nylon “hats” that are stylistically derived from four vernacular roofs—barrel, gable, butterfly, and double gable—rescaled to fit the structures neatly while also offering modular configurations.



W. Jude LeBlanc's proposal *Kite/Folly* combines a camera crane, tripod, and textile canopy to create a hoisted, column-less tent that "provides a roof without restricting open space." The proposal's elegance lies in its functional economy: individually, it can provide shade to a small picnic gathering or subdivide larger spaces; when arranged adjacent to one another, they delineate a collective functional space to host events and activities like farmer's markets.



Manson Fung's *Adaptive Permutations* deconstructs a prototypical shelter into smaller module components, allowing for myriad groupings to accommodate the often overlooked “nuanced beauties of everyday patterns.” Each individual module has three foldable steel legs, allowing it to stand on its own, which, when deployed in conjunction with other modules, can be rotated inwards to function as a single column in support of a composite canopy structure.



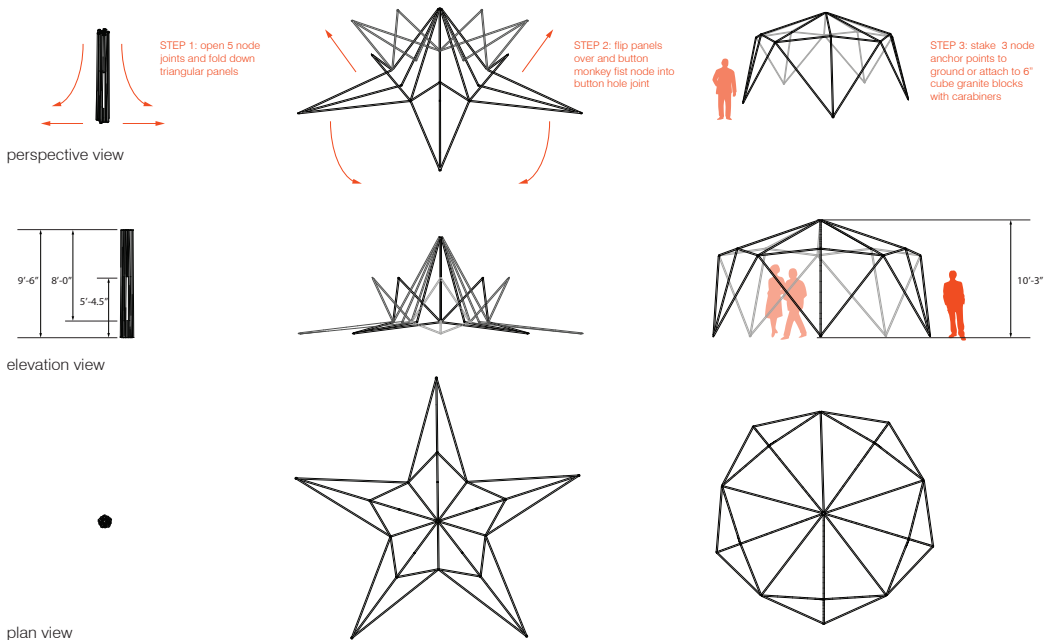

Naomi Darling and **Ray K. Mann** are inspired by architect Santiago Calatrava's folding and irregularly-supported structures in their proposed dodecahedral *Kasa Pavilion*. By employing the Moku hitching technique, incorporating lines of identical and opposite tension across a shared ring, the nodal joints permit a certain degree of flexibility while maintaining structural integrity.

Portal, proposed by **Edward Hsu**, is a set of perforated wood panels arranged in a cubic configuration with two open and two closed sides, joined by interlocking corners to create a large 8x8 foot interior space. Evoking the rich history of architectural follies shaping the viewer's experience of the landscape, *Portal* frames the Park's vistas of the East River and Manhattan skyline. When constructed adjacent to one another, the structures form a tunnel enclosing a long rectangular space or a collection of functional stalls.



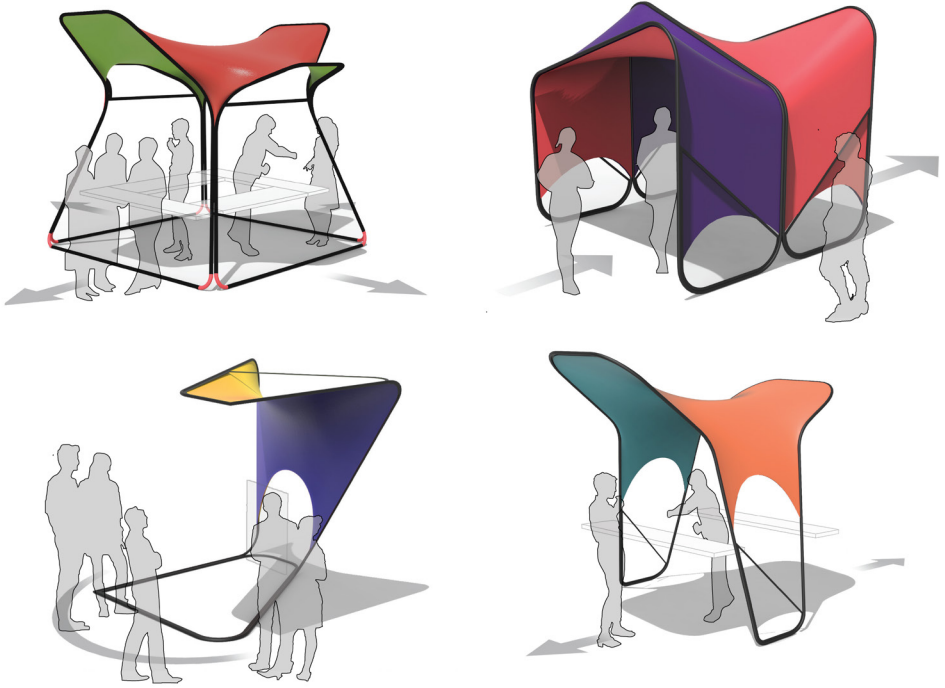

Palette Architecture critiques the ubiquitous pyramid tent as “designed for an overly general use case” and adapts its form to accommodate more specialized and “realistic” purposes in their proposal *Flex-Tents*. The shading structures consist of dual-layered stretch fabric (the “canopy piece”) hugging a steel wall tube frame, with ball-bearing ballasts and horizontal “stiffeners” utilized to enhance stability and resistance to wind. All exhibiting different configurations and directionalities, the tents are meant to “suggest a spectrum of possibilities” to “address the various programmatic needs” of the Park.

Harrison Atelier proposes *Tearcatchers*, “a black skeletal framework that is light-weight, collapsible, and designed to channel rainwater along the u-channels defining its roof and walls.” A modern, architectural iteration of the lachrymatory (tearcatcher), a centerpiece of Victorian mourning culture, the follies respond to the current political climate by presenting, and lamenting, environmental degradation in miniature.

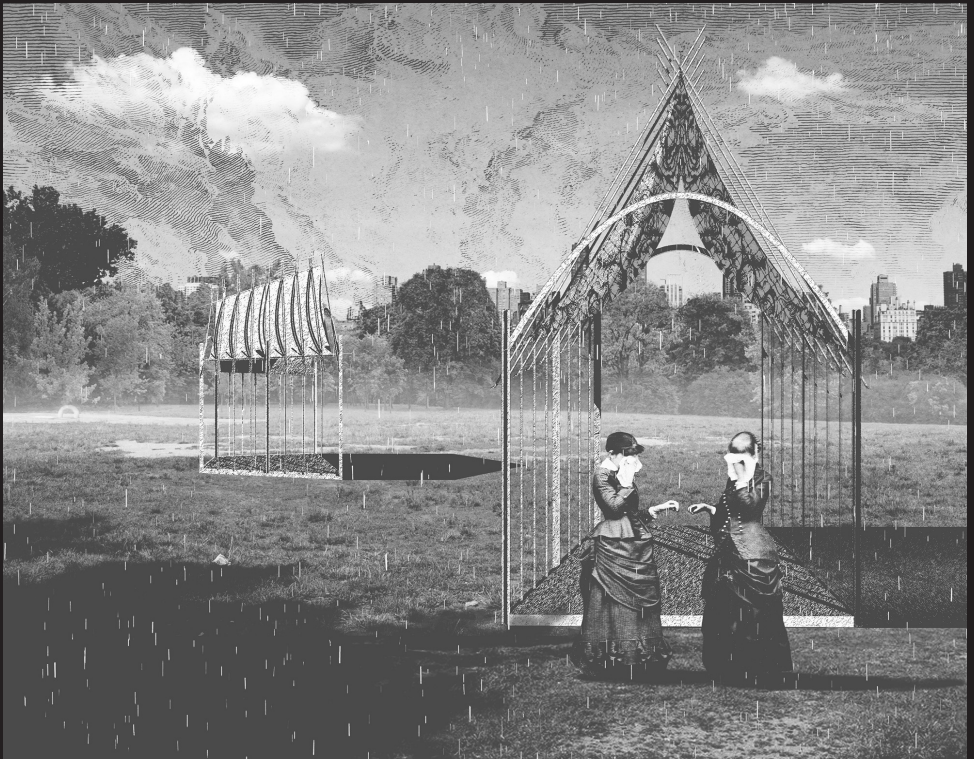

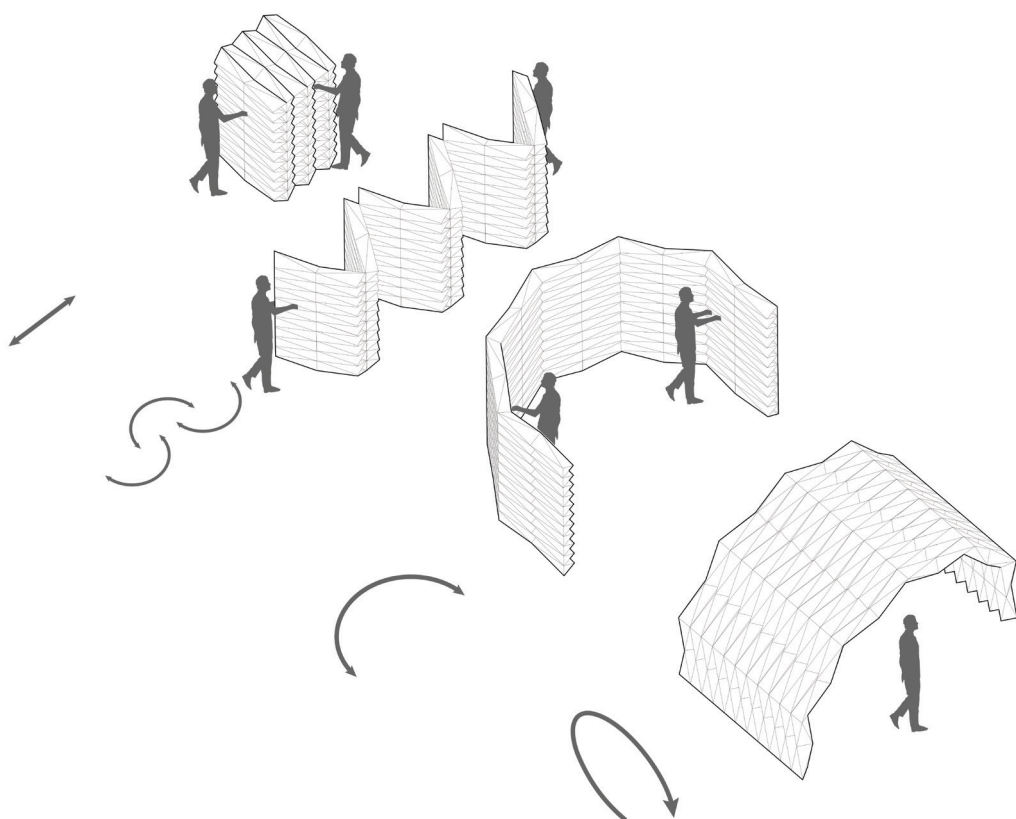

The Principals emphasize material transience and peripatetic utility in their theoretical conception *Head Gear*, proposing “a folded, coroplast cell-based structure... tensioned into place by a simple ratchet strip.” These recyclable, lightweight “architectural teeth” are easily unfolded and tensioned for support, and claim to challenge both the solidity and activity of buildings and the boundaries of what constitute the “built environment.”

some days were lazy...

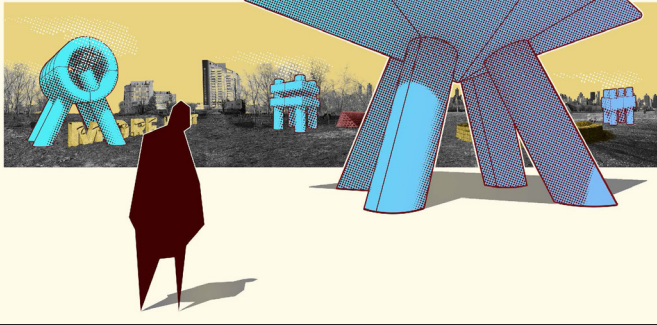

Seizing upon the Park's capacity to inspire dialogue between current and past sculptures and installations, as well as its eclectic visitors, **Mark Zlotsky**, **Karyn Lao**, and **Maxx Berkowitz** propose *four wise cattle / The Cattle*. Four inflatable structures of different shapes and configurations “impose a monumental presence” and “invite you to enjoy their shade and wander amidst their hazy breath.” Like livestock, these Cattle can be found wandering about the Park, sharing individual interactions with visitors, or “put to work—whipped into line to organize a bazar or huddled into a square to shade a meeting.”



about Eva Jensen Design



Eva Jensen Design (EJD) is an award-winning New York-based architecture and interior design studio founded by Danish architect Eva Christine Jensen, AIA, MAA. EJD offers international experience rooted in the Danish design tradition, and works in a full range of design projects with a niche in high-end residential architecture and interiors, furniture design, and art installations. EJD emphasizes attention to detail and aspires to create thoughtful spaces that connect people to nature, with a focus on light and cohesiveness, striving for innovation and authentic design solutions.

Throughout her body of work, Eva Christine Jensen has aspired to develop designs to the highest set of standards, and to distill towards essence and to unify detail, structure, and space into a cohesive whole. At different points throughout her career, as an assistant professor at the Royal Academy of Fine Arts, School of Architecture in Copenhagen and later as a practicing architect in Denmark and the United States, she has dedicated time to in-depth research studies resulting in installations and exhibitions. Inspiration is drawn from juxtaposing architectural history studies with contemporary design, nature, material, and technology research. Designing and fabricating the *Circle Shade* project has been an important milestone for the studio. At the same time, it also represents a natural evolution of the architecture and interior furniture design the office has created.









o FOLLY/FUNCTION 2017 o CIRCLE SHADE-2TR4 o

o FOLLY/FUNCTION 2017 o CIRCLE SHADE-2TR4 o

o FOLLY/FUNCTION 2017 o CIRCLE SHADE-2TR4 o

SUPPORT

&

THANKS

This program is funded, in part, by public funds from the New York State Council on the Arts with the support of Governor Andrew Cuomo and the New York State Legislature, and from the New York City Department of Cultural Affairs in partnership with the City Council.

Socrates Sculpture Park's exhibition program is also supported by the generosity of Bloomberg Philanthropies, Charina Endowment Fund, Paula Cooper, Mark di Suvero, Sidney E. Frank Foundation, Maxine and Stuart Frankel Foundation for Art, Agnes Gund, The Lily Auchincloss Foundation, The Henry Luce Foundation, The Kayden Family, Lambent Foundation Fund of Tides Foundation, Ivana Mestrovic, Nancy Nasher and David Haemisegger, Joel Shapiro and Ellen Phelan, Plant Specialists, Silvercup Studios, Mr. and Mrs. Thomas W. Smith, Spacetime C. C., and our generous Board of Directors.

Special thanks to the City of New York, Mayor Bill de Blasio, Queens Borough President Melinda Katz, City Council Speaker Melissa Mark-Viverito, Assemblywoman Catherine Nolan, Council Members Jimmy Van Bramer and Costa Constantinides, and New York City Department of Parks and Recreation Commissioner Mitchell Silver. *Circle Shade* was conceived by principal Eva Christine Jensen, AIA, MAA, and developed and fabricated in collaboration with EJD design team: Sushwala Hedding and David Rowan Johnson.

Structural engineering consulting and joint node development and fabrication was realized in collaboration with Laufs Engineering Design, LLC and Jeffrey Montes. Many thanks to all, including Jacqueline Mix, Chris Zirbes, and Terrence McCrutchin, for assistance with on-site fabrication.

Eva Jensen Design wishes to express special thanks to the gifted and generous group of fabricators and photographers who we had the opportunity to collaborate with on the *Circle Shade* project:

Truth Concrete with John Alliegro for fabrication of the mold cast concrete counterweights

Manhattan Shade & Glass with Mitchell Schulman for fabrication of the canopy membranes

Reflect Printing & Graphics with Robert Szent for print services and logo application film for the canopies

Phorm Inc for CNC milling of counterweight seats and jigs

Z-Studios with Zach Zaus for bending of ring segments for the canopies

Jonathan Pilkington, photographer for press package photographs and stop-motion assembly video

Folly is a partnership between Socrates Sculpture Park and The Architectural League of New York, and is directed jointly by Jess Wilcox, Director of Exhibitions, Socrates Sculpture Park, and Anne Rieselbach, Program Director, The Architectural League of New York.

Photography, renderings and images courtesy of Eva Jensen Design, LLC. Press packet photographs and stop-motion video by Jonathan Pilkington Photographer. Event photographs courtesy of The Architectural League, Ricardo Mejias, Sara Morgan, and Gilbert Santana.

Editor Jordan Hruska

Associate Editor Akiva Blander

Design Ricardo Mejias and Megan Lee

Socrates Sculpture Park
32-01 Vernon Boulevard
Long Island City, NY 11106 USA
718-956-1819

Open daily from 9am until sunset
Free admission

Socrates Sculpture Park Board

Stuart March Suna, President

Robert F. Goldrich

Ivana Mestrovic, Secretary and Treasurer

Maxine Frankel

Richard Gluckman, FAIA

Deidrea Miller

Brooke Kamin Rapaport

Ursula von Rydingsvard

Joel Shapiro

Thomas Smith

Kimberly Strong

Commissioner Mitchell Silver, Ex-Officio

Mark DiSuvero, Chair Emeritus

Staff

John Hatfield, Executive Director

Audrey Dimola, Director of Public Programs

Katie Denny Horowitz, Director of External Affairs

Terrence McCrutchin, Operations Assistant

Sara Morgan, Development and Communications Assistant

Maya Reyes, Arts Education Fellow

Jess Wilcox, Director of Exhibitions

Chris Zirbes, Studio and Facilities Manager

About the Partners

The Architectural League of New York nurtures excellence in architecture, design, and urbanism, and stimulates thinking and debate about the critical design and building issues of our time. As a vital, independent forum for architecture and its allied disciplines, the League helps create a more beautiful, vibrant, innovative, and sustainable future. For more information visit archleague.org

Founded in 1986, **Socrates Sculpture Park** is the only site in the New York metropolitan area specifically dedicated to providing artists with opportunities to create and exhibit large-scale sculpture and installations in a unique outdoor environment that encourages strong interaction between artists, artworks, and the public. The park's existence is based on the belief that reclamation, revitalization, and creative expression are essential to the survival, humanity, and improvement of our urban environment.



**SOCRATES
SCULPTURE
PARK**

**T H E A R C H I
T E C T U R A L
L E A G U E N Y**



**T H E A R C H I
T E C T U R A L
L E A G U E N Y**